

Accessories

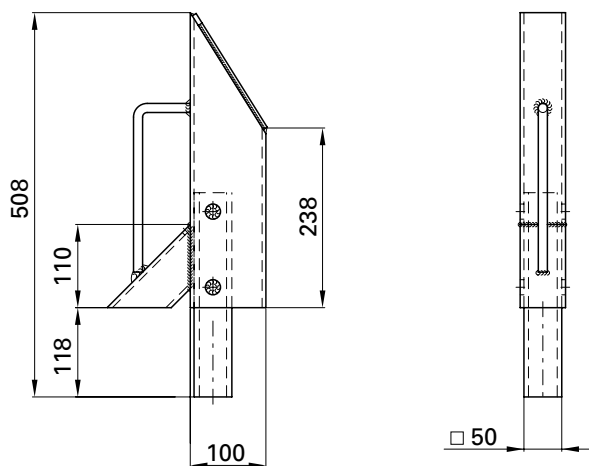

Application: Stud for winglock

Application: Support tool for containers to replace the standard pins in the winglock.

Surface: hot-dip galvanised

Selection table / available versions

Weight (kg)	Order No.	Drawing No.
7.0	410.140.500	410.140.500

Accessories

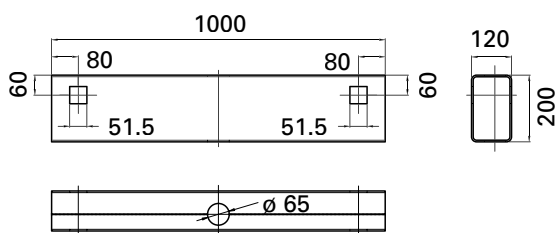

Center section

Accessories for 40' position

Selection table / available versions

Weight (kg)	Order No.	Drawing No.
23.0	410.140.100	410.140.000

Surface: Center section raw and inserts raw, locking parts galvanised.

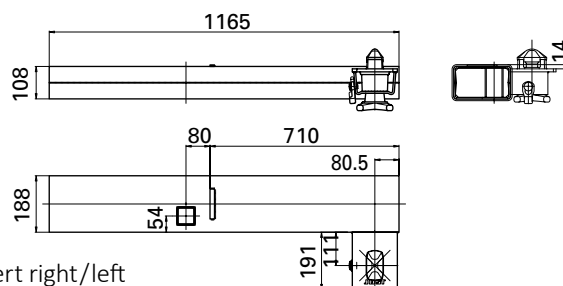

Insert right/left

Accessories for 40' position

Selection table / available versions

Version	Weight (kg)	Order No.	Drawing No.
right	28.0	410.140.210	410.140.210
left	28.0	410.140.220	410.140.220

Stop

Application : For positioning of the container in the direction of travel on the vehicle or trailer.

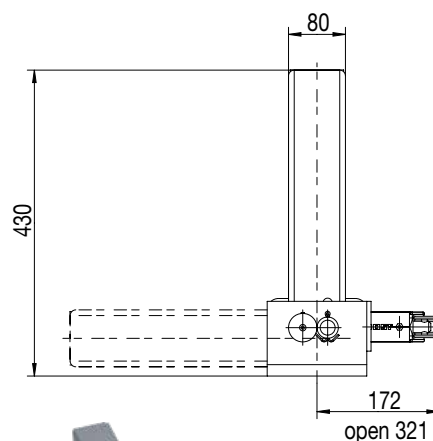
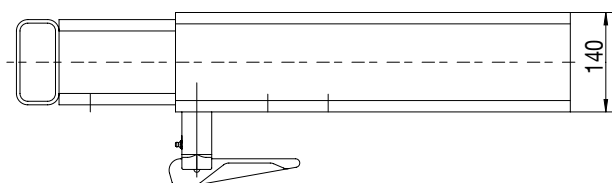
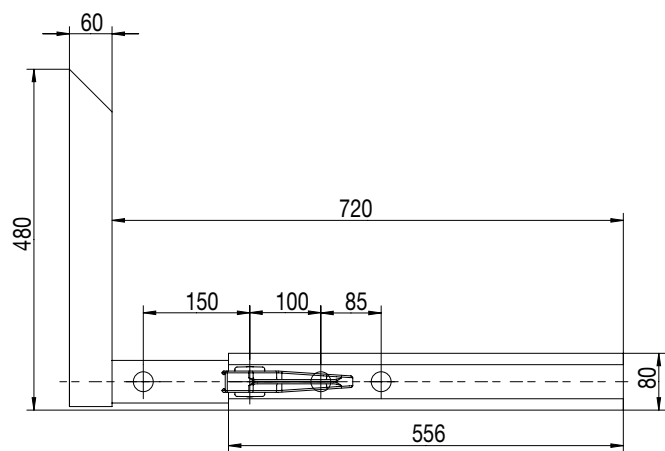
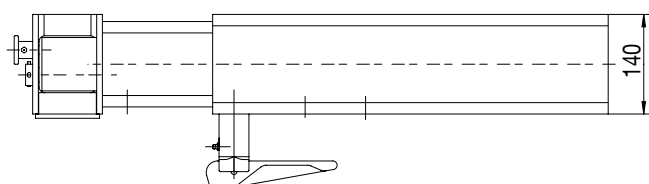
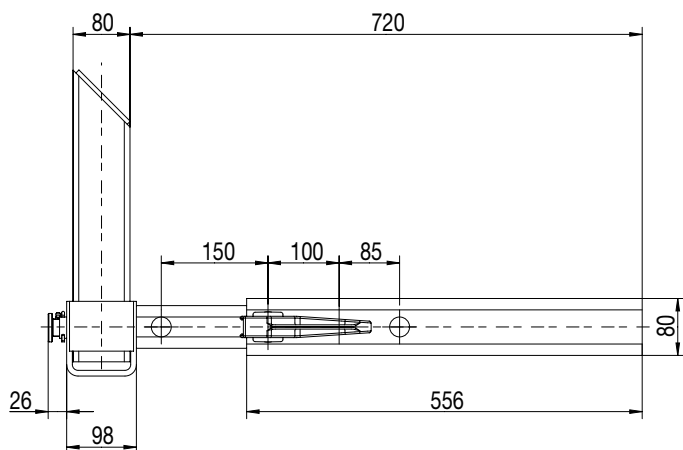

ASW 160

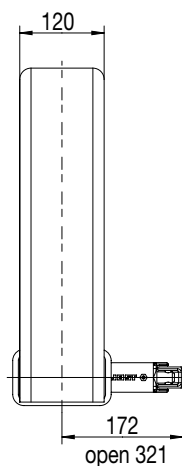

ASW 160 HR

Selection table / available versions

Model	Weight (kg)	Order No.	Drawing No.
folding	34.0	ASW 160	410.147.000
fixed	27.0	ASW 160 HR	410.152.000

Stop is delivered primed