

# Security latch with a short and a long front latch

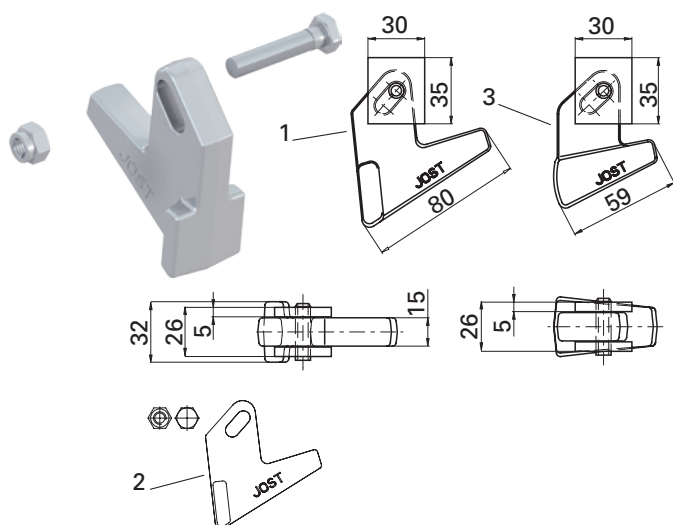

Application: To secure the clamp nuts on twist locks and bolsters to prevent their being released accidentally.

## Selection table / available versions

Item	Versions	Weight (kg)	Order No.
1	long front latch with holder	0.5	905.396.000
2	long front latch screwable	0,5	905.396.500
3	short front latch with holder	0.4	905.320.000

# Security latch standard

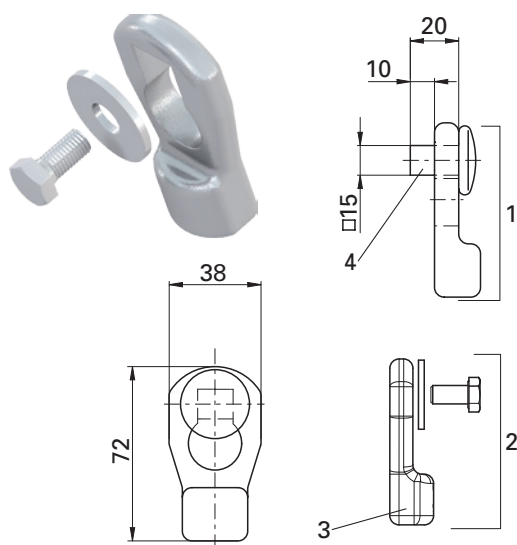

Application: To secure the clamp nuts on twist locks and bolsters to prevent their being released accidentally. Suitable for all twist locks except F 10 SK, R 411 VAK, R 316 VAP and R 306 VAP.

Material: Steel

## Selection table / available versions

Item	Versions	Weight (kg)	Order No.
1	Weldable, complete	0.25	905.159.000
2	Screwable, complete	0.25	905.159.500
3	Latch	0.15	915.159.001
4	Pin	0.10	905.159.002

# Ball lock

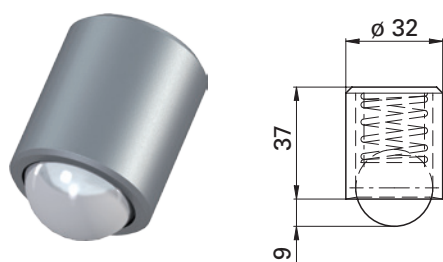

Application: To secure the clamp nuts on twist locks and bolsters to prevent their being released accidentally. Suitable for all twist locks F 10 SK, R 411 VAK, R 316 VAP, R 305 VAP and comparable versions.

## Selection table / available versions

Versions	Weight (kg)	Order No.
Steel	0.1	905.000.143